

# Precision Regulator (SRP)

## SRP2000~3000 Series



SRP 2000



SRP 3000

### How to order

SRP 20 00 - 02 BG

- ① Precision Regulator
- ② **Body Size**
  - 20 - 1/4
  - 30 - 3/8
- ③ **Regulating pressure range**
  - 00 - 0.2~8 bar
  - 20 - 0.1~2 bar
  - 40 - 0.1~4 bar
- ④ **Thread type**
  - Nil - Rc(PT)
  - N - NPT
  - G - G(PF)
- ⑤ **Port Size**

Symbol	Size	Body size	
		20	30
02	1/4	●	
03	3/8		●
04	1/2		●
- ⑥ **Accessory(Optional)**
  - Nil - None Bracket / None Gauge
  - B - Bracket
  - G - Precision Gauge

### Symbol

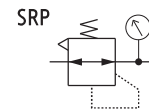

### Specification

Fluid	Compressed Air	
Max. operating pressure	10bar (1.0MPa)	
Min. supply <sup>1)</sup> pressure	SRP2000	Set pressure +0.5bar
	SRP3000	Set pressure +1bar
Regulating range	0.2~8bar (0.02~0.8MPa)	
	0.1~4bar (0.01~0.4MPa)	
	0.1~2bar (0.01~0.2MPa)	
Sensitivity	Within 0.2% of full span	
Repeatability	Within ±0.5% of full span	
Air consumption <sup>2)</sup> (At supply pressure of 10bar)	SRP2000	5 L/min
	SRP3000	11 L/min
Ambient and fluid temperature	-5~60°C (No freezing)	
Gauge port	1/8	
Port size	SRP2000	1/4
	SRP3000	3/8, 1/2

Note : 1. With the condition of no flow on the output side.

2. Air is normally being discharged to the atmosphere from a bleed hole or an exhaust port.

### Precautions

- ① If the supply pressure line contains drainage, particulate, or other debris, the fixed throttle can become clogged leading to malfunction. To avoid malfunctions, in addition to an air filter (Series SAF), installation of a mist separator (Series SAM, SAFM) is required.
- ② If the drain removal from air filter and mist separator is missed, drain will be flown out to the outlet side and may result in a malfunction of the pneumatic equipment. When removing drain is difficult, use of a filter with an autodrain is recommended.
- ③ Never use a lubricator on the supply side of the regulator, as this will positively cause the fixed throttle to become clogged and result in a malfunction. If lubrication is required for terminal devices, connect a lubricator on the output side of the regulator.
- ④ If a directional switching valve (solenoid valve, mechanical valve, etc.) is mounted on the supply side of the regulator and repeatedly switched ON and OFF, wear of the nozzle/flapper section will be accelerated and a discrepancy in the setting value may occur. Therefore, avoid using a directional switching valve on the supply side. In the event a directional switching valve will be used, install it on the output side of the regulator.
- ⑤ Air is normally released from the bleed hole (the hole on the side of the body's mid-section). This is a necessary consumption of air based on the construction of the precision regulator, and is not an abnormality.

# Series SRP2000~3000

## FLOW CHARACTERISTICS Supply pressure : 1MPa

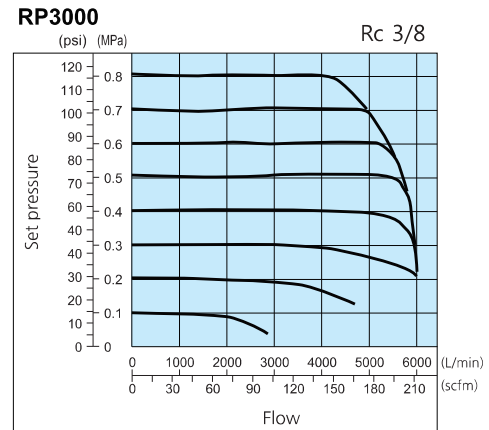
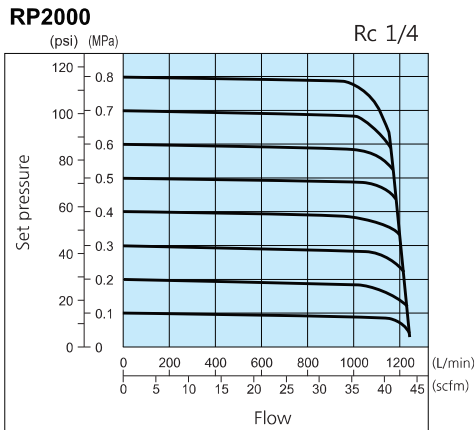

## RELIEF CHARACTERISTICS Back pressure : 1MPa

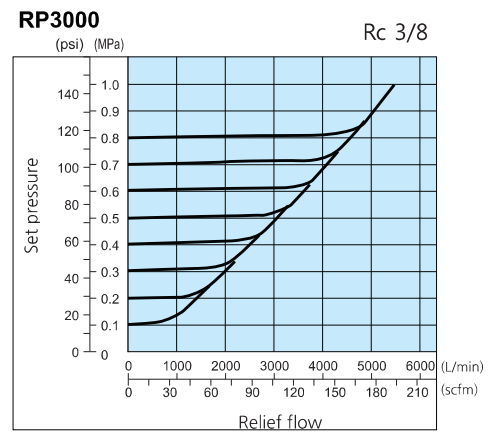
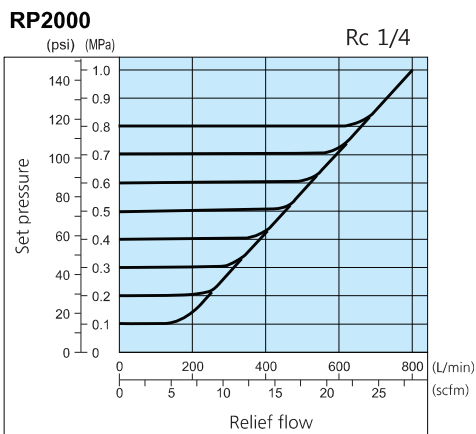

## PRESSURE CHARACTERISTICS Supply pressure: 0.7 MPa, Set pressure: 0.2 MPa, Flow rate: 0 L/min (ANR)

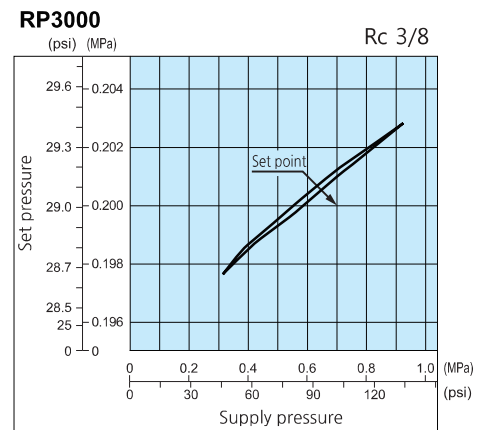
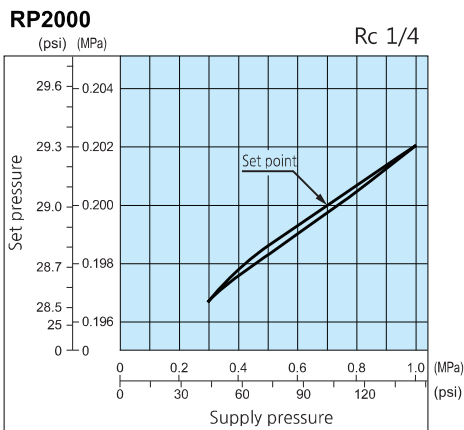

## STRUCTURE / PARTS

**SRP2000**

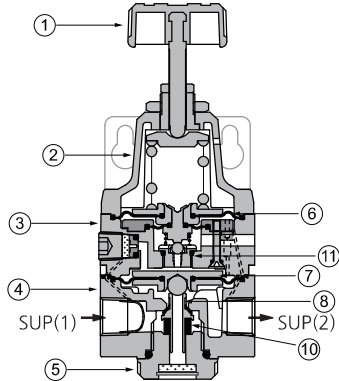

### ■ Working principle (For SRP2000)

When the knob is turned, the nozzle closes by the flapper, allowing supply pressure(SUP(1)) to enter and pass through fixed orifice and apply on diaphragm ⑦ as back pressure. Back pressure causes check valve ⑧ to be pushed down to allow supply pressure to flow out to the downstream side(SUP(2)). Supply pressure applied to Diaphragm ⑦ also is applied to Diaphragm ⑥ which creates an opposing force against compression force of the setting spring and becomes the set pressure.

When set pressure increases significantly, Diaphragm ⑥ is pushed up and space between flapper and nozzle widens causing nozzle back pressure to drop. Drop in nozzle back pressure causes Diaphragm ⑦ drop, closes the check valve ⑧ and opens the exhaust valve.

Precise pressure adjustment is achieved by using this nozzle flapper type mechanism.

**SRP3000**

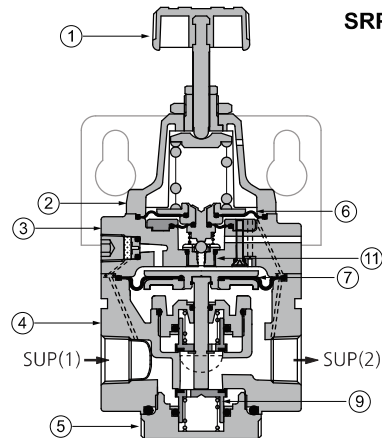

### ■ Component Parts

No.	PARTS	MATERIAL
①	Handle	NYLON
②	Cover	ALDC
③	Disk	ALDC
④	Body	ALDC
⑤	Valve guide	ALDC

### ■ Replacement Parts

No.	PARTS	MATERIAL
⑥	Diaphragm Ass'y	NBR, others
⑦	Main Diaphragm Ass'y	NBR, others
⑧	Check valve	SUS, NBR
⑨	Check valve	Brass, NBR
⑩	Damper	NBR
⑪	Nozzle Ass'y	Brass, others

## DIMENSIONS (mm)

**SRP2000**

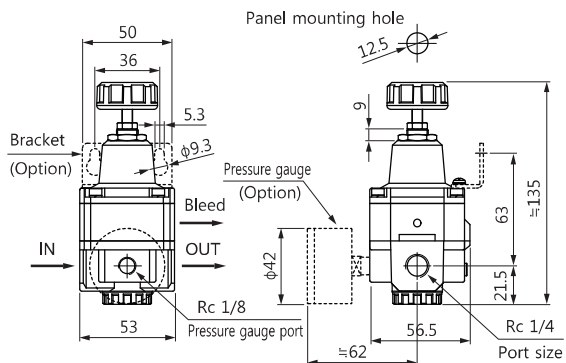

**SRP3000**

