

Air Unit (SAU240~440 Series)

Filter Regulator + Mist Separator



SAU 240



SAU 340



SAU 440

How to order

SAU 4 40 - 04 DG - MeP

- Air Unit**
- Body Size**
2 - 1/4
3 - 3/8
4 - 1/2
- Composition**
40 — Filter Regulator(SAW)
Mist Separator(SAFM)
- Thread type**
Nil - Rc(PT)
N - NPT
G - G(PF)
- Port size**

기호	사이즈	몸체 사이즈		
		2	3	4
01	1/8	●		
02	1/4	●	●	
03	3/8		●	
04	1/2			●
06	3/4			●
- Accessory(Optional)**
Nil - None gauge / Manual Drain
D - Auto Drain

Symbol	Description	Body		
		2	3	4
D	One-touch fitting type	●	●	●
Dn	Nipple(PT1/8) type	-	●	●
Df	SAW,SAFM200 Float type	●	-	-

주) 1. SAW, SAFM200 are differential pressure type.
2. SAW, SAFM300~400 are float type.

G	Round type gauge
Gs	Square embedded type
- Bowl**
Nil - Polycarbonate bowl with Nylon guard
PcS - Polycarbonate bowl with Steel guard
MeP - Metal bowl with pipe type sight glass

Symbol

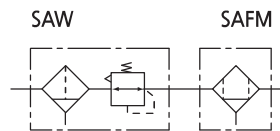

Specification

Composition	Filter Regulator + Mist Separator
Fluid	Compressed Air
Max. operating pressure	10bar (1.0MPa)
Max. supply pressure	15bar (1.5MPa)
Ambient and Media temp.	-5 ~ 60°C (No freezing)
Regulating range(SAW)	0.5~8.5bar (0.05~0.85MPa)
Filtration	SAW:10µm + SAFM:0.1µm
Bowl material(SAW, SAFM)	Poly-carbonate (option: ALDC)
Construction(SAW)	Relief type

Precautions

- Do not use Poly-carbonate bowls in an environment where they are exposed to or come in contact with organic solvents, chemicals, cutting oil, synthetic oil, alkali, and thread lock solutions.
- Components with a bowl must be installed vertically with the bowl downward so that faulty drain discharge and dripping can be verified.
- Set the outlet pressure range for the regulator in a range that is 85% or less of the inlet pressure. If set above 85%, the inlet pressure will be easily effected by fluctuations in the flow rate and inlet pressure, and will become unstable.
- To set the pressure using the knob, turn the knob in the direction that increases pressure and lock the knob after the pressure is set. If this is done in the direction that decreases pressure, the pressure may drop from the original set pressure. Turning the knob clockwise increases the outlet pressure, and turning it counterclockwise reduces the pressure.
- When auto drain is used, drain piping should be both 4mm or greater in diameter and less than 1m in length. Avoid installing drain piping upwards.
- When auto drain is inoperable, drain manually by pushing the one-touch fitting upward.

DIMENSIONS (mm)

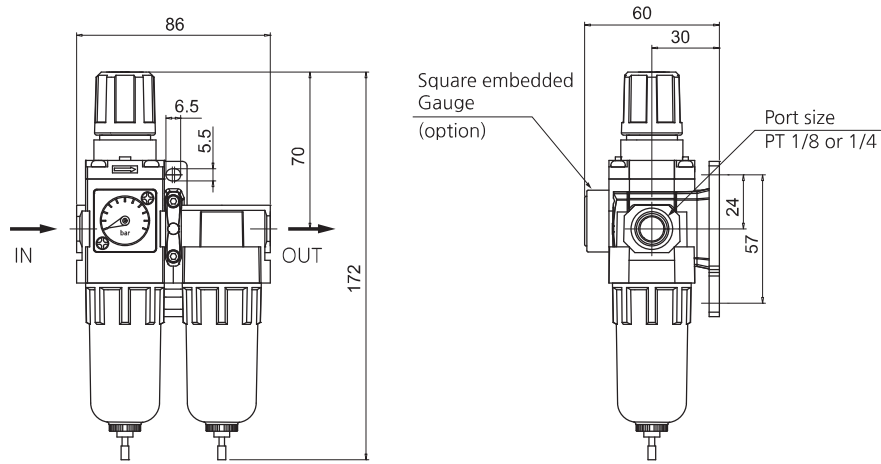

SAU 240

■ SAU240-□02□□-□

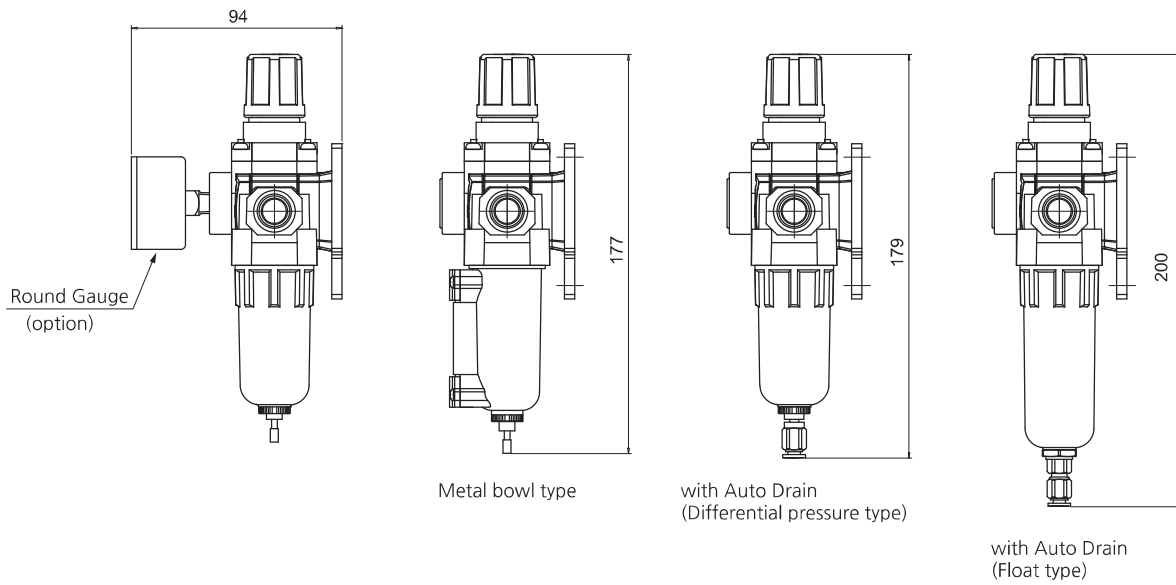

■ Dimensions of each model with an option attached

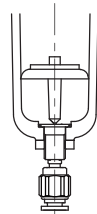
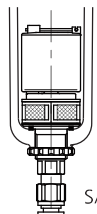

Option	Auto Drain		Gauge	
	D : Differential pressure type	Df : Float type	G : Round type	Gs : Square embedded type
Model		 SAD200	 G40, R1/8	 Gs28

Series SAU240~440

DIMENSIONS (mm)

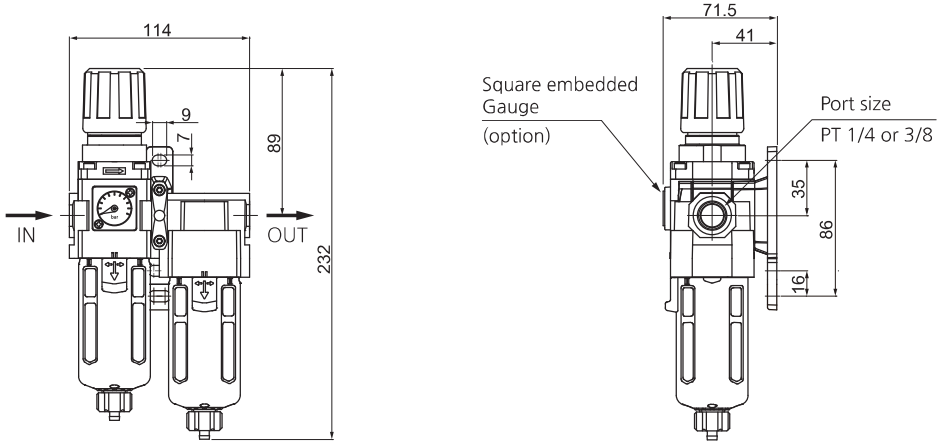

SAU 340

- SAU340-□03□□-□

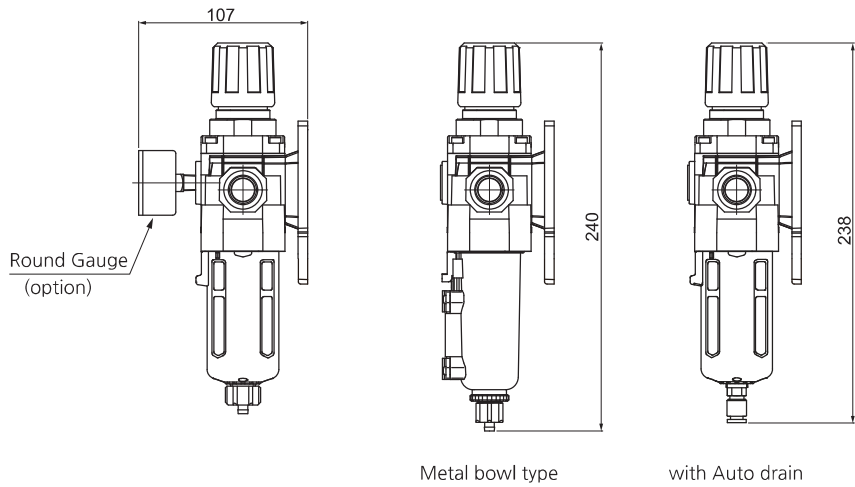

- Dimensions of each model with an option attached

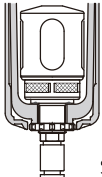

Option	D : Auto Drain	Gauge	
		G : Round type	Gs : Square embedded type
Model	 SAD300	 G40, R1/8	 Gs28

DIMENSIONS (mm)

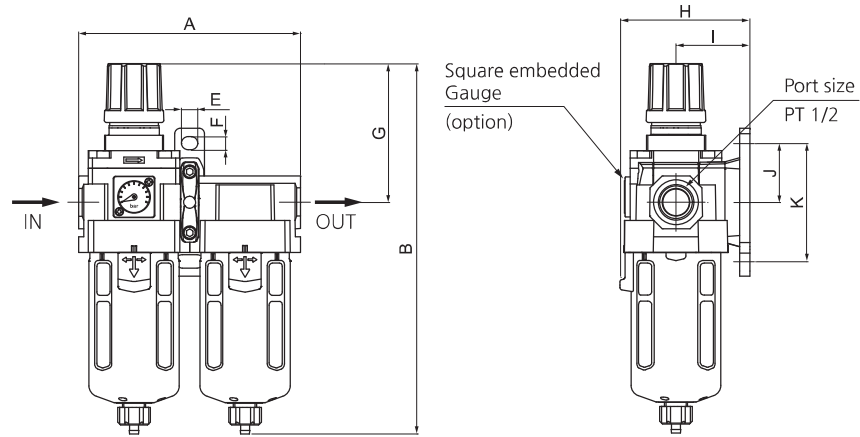

SAU 440

- SAU440-□04(06)□□-□

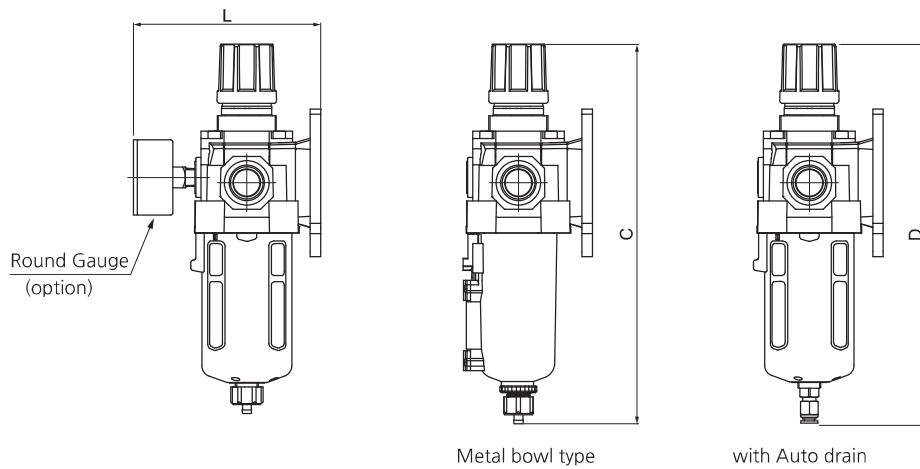

- Dimensions of each model with an option attached

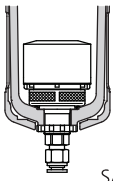

Option	D : Auto Drain	Gauge	
		G : Round type	Gs : Square embedded type
Model	 SAD400	 G50, R1/4	 Gs28

Model	Port size	A	B	C	D	E	F	G	H	I	J	K	L
SAU420-04	1/2	150	251	254	258	11	9	94	87.5	50	40	80	127
SAU420-06	3/4	150	256	259	263	11	9	94	87.5	50	80	40	127