

# Air Regulator (SAR)

## SAR100~600 Series

- With the backflow function, the SAR series incorporates a mechanism which exhausts the air pressure through the outlet side efficiently.



SAR600



SAR400



SAR300



SAR200



SAR100

### How to order

**SAR 4 00 - 04 BGK**

① Air Regulator

② Body Size

- 1 - 1/8
- 2 - 1/4
- 3 - 3/8
- 4 - 1/2, 3/4
- 6 - 1

③ Thread type

- Nil - Rc(PT)
- N - NPT
- G - G(PF)

④ Port Size

Symbol	Size	Body size					
		1	2	3	4	6	
M5	M5	●					
01	1/8		●				
02	1/4		●	●			
03	3/8			●			
04	1/2				●		
06	3/4				●	●	
10	1					●	

⑤ Accessory(Optional)

- Nil - None Bracket / None Gauge
- B - Bracket
- G - Gauge

G	Round type
Gs	Square embedded type

Note) SAR100 is available only round type gauge.

K - With backflow function

Note) SAR100 can not attach a backflow function.

### Symbol

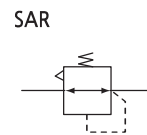

SAR with backflow function

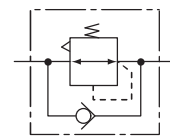

### Specification

Fluid	Compressed Air				
Max. operating pressure	10bar (1.0MPa)				
Max. supply pressure	15bar (1.5MPa)				
Ambient and Media temp.	-5~60°C (No freezing)				
Regulating range	0.5~8.5bar (0.05~0.85MPa)				
Gauge port	SAR100	SAR200	SAR300	SAR400	SAR600
	1/16	1/8		1/4	
Construction	Relief type				

### Precautions

- ① Set the outlet pressure range for the regulator in a range that is 85% or less of the inlet pressure. If set above 85%, the inlet pressure will be easily effected by fluctuations in the flow rate and inlet pressure, and will become unstable.
- ② To set the pressure using the knob, turn the knob in the direction that increases pressure and lock the knob after the pressure is set. If this is done in the direction that decreases pressure, the pressure may drop from the original set pressure. Turning the knob clockwise increases the outlet pressure, and turning it counterclockwise reduces the pressure.
- ③ Please contact SKP when a circuit requires the use of a regulator having relief sensitivity with high precision and setting accuracy.
- ④ Residual pressure release (outlet pressure release) is not complete by releasing the inlet pressure. To release residual pressure, select a model with a back flow mechanism.

# Series SAR100~600

## FLOW CHARACTERISTICS

Inlet pressure 7kg/cm<sup>2</sup>

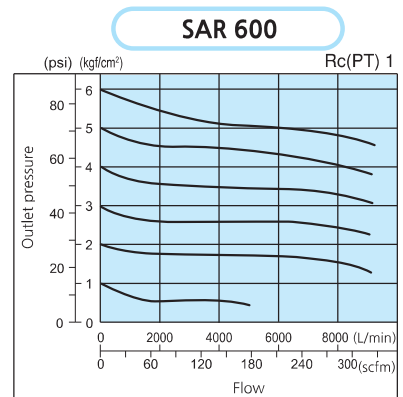
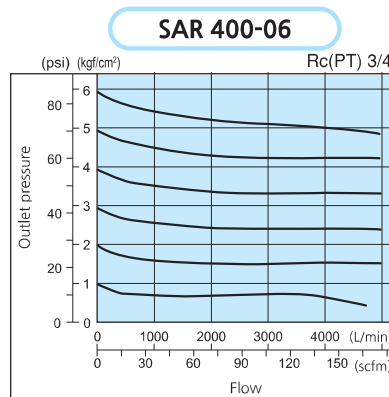
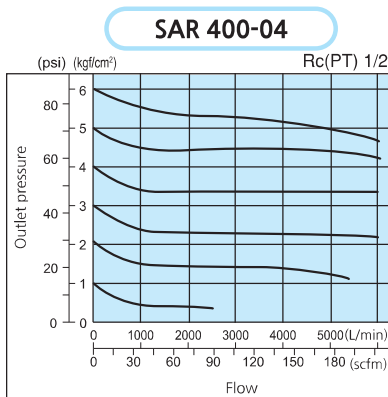
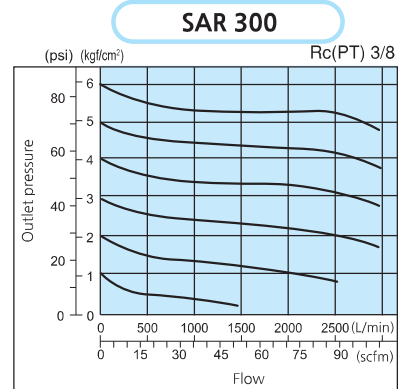
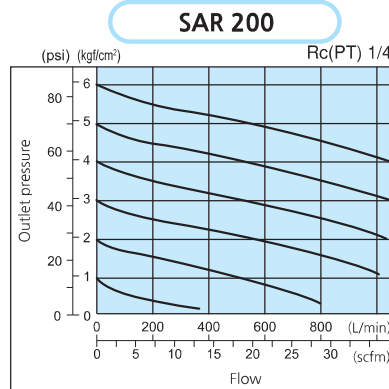
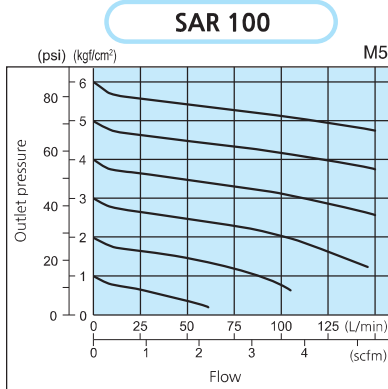

## PRESSURE CHARACTERISTICS

Inlet pressure 7kg/cm<sup>2</sup>, Outlet pressure 2kg/cm<sup>2</sup>, Flow 20L/min(ANR)

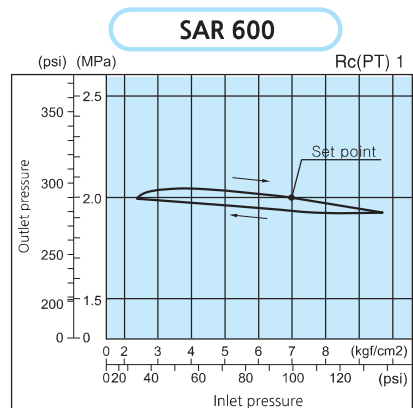
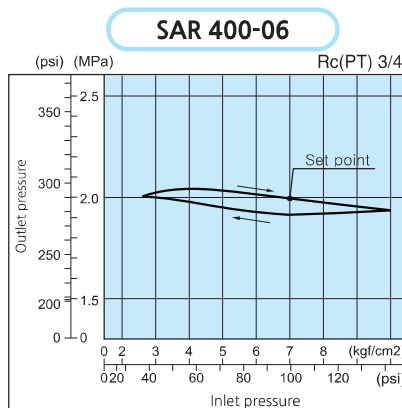
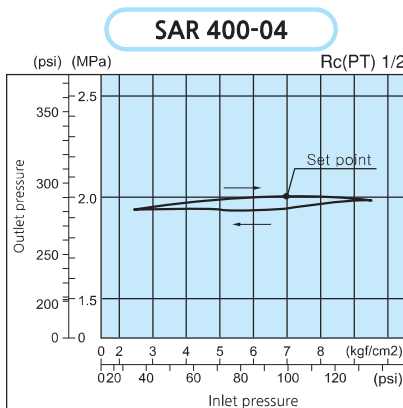
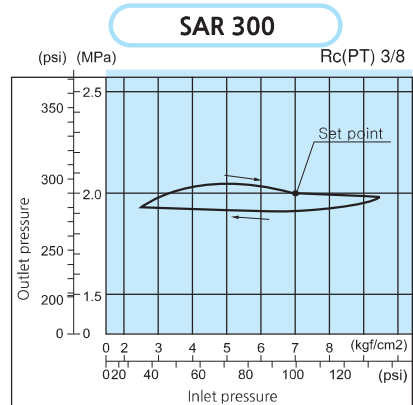
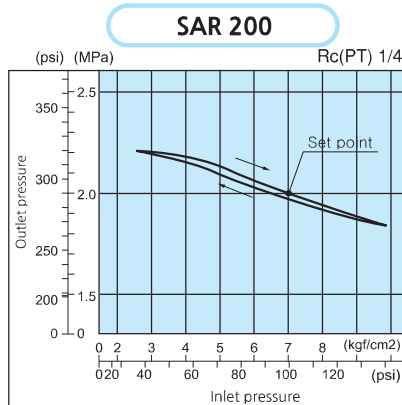
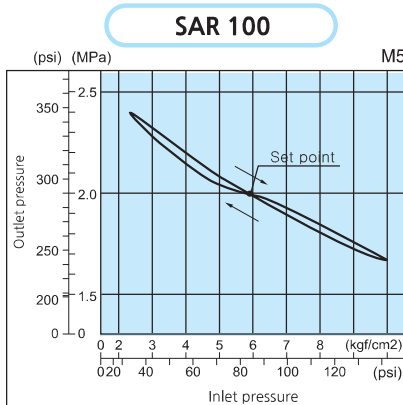

## STRUCTURE / PARTS

SAR100

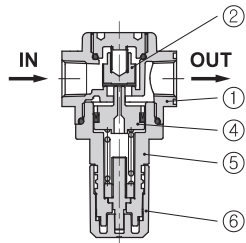

SAR200

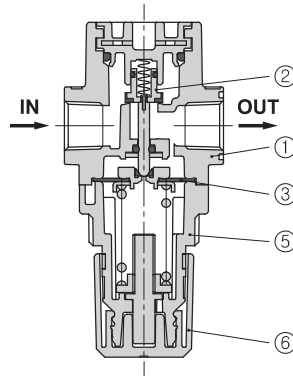

SAR300 to 600

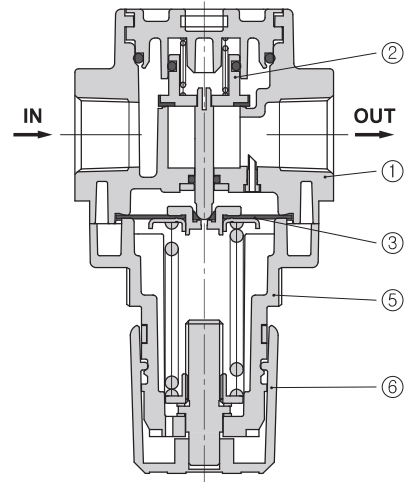

### ■ Component Parts

No.	PARTS	MATERIAL
①	Body	ALDC
②	Check valve Ass'y	Brass, NBR
③	Diaphragm Ass'y	NBR
④	Piston <sup>1)</sup>	N66G
⑤	Cover <sup>2)</sup>	N66G
⑥	Handle	ABS

Note : 1. The SAR100 is a piston type. Assembly of a piston and a seal.  
 2. SAR600 cover material is ALDC

# Series SAR100~600

- Backflow function adapter
- Regulator with Backflow function adapter installed.

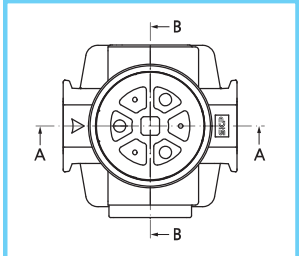
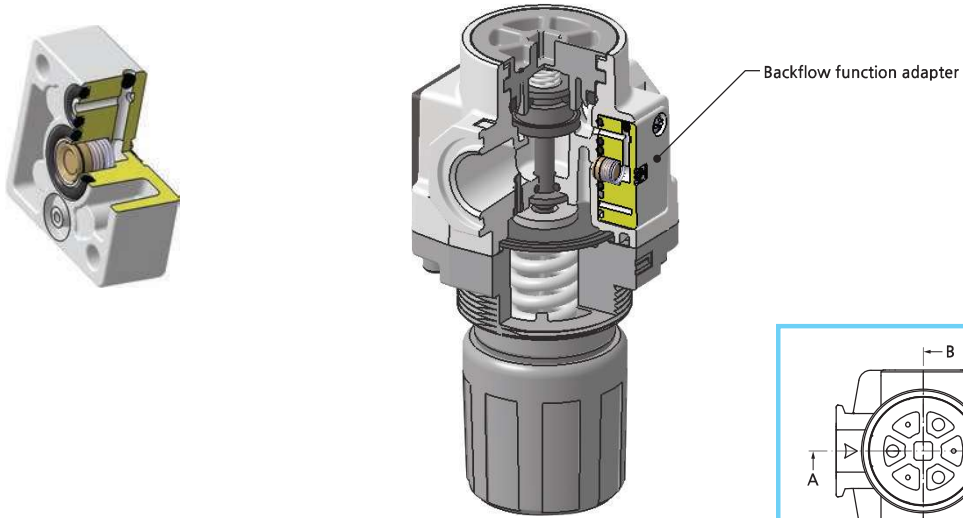

- AR200~600, AW200~600

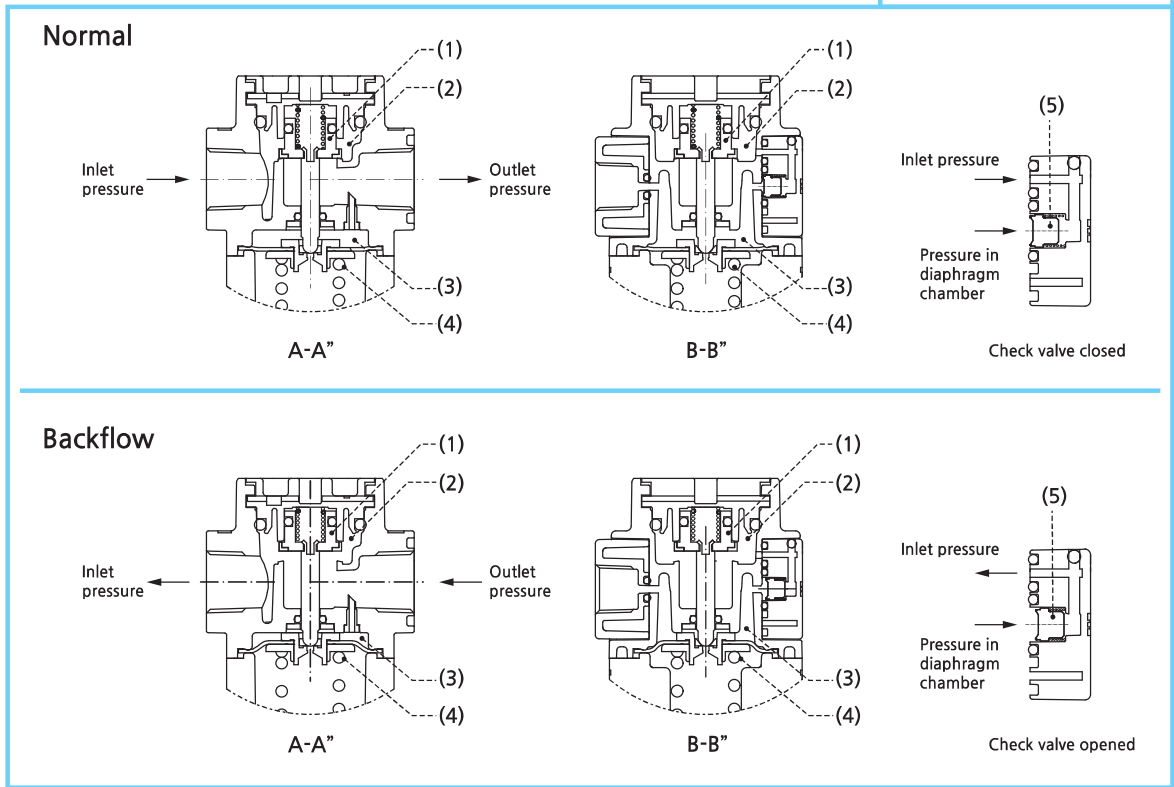

work	Description for the operation state by the backflow function adapter
normal	Because the inlet pressure(1) is higher than the regulating pressure, Check valve(5) closes and operates as a normal regulator.
backflow	When the inlet pressure(1) is shut off and released, the pressure in the diaphragm chamber (3) is released into the inlet side(1) to open the check valve(5). This lowers the pressure in the diaphragm chamber(3) and the force generated by the pressure of the regulator cover spring(4) opens the regulator check valve(2) The outlet pressure is released to the inlet side(1)

## DIMENSIONS (mm)

### SAR 100

- SAR100-□01(M5)□□

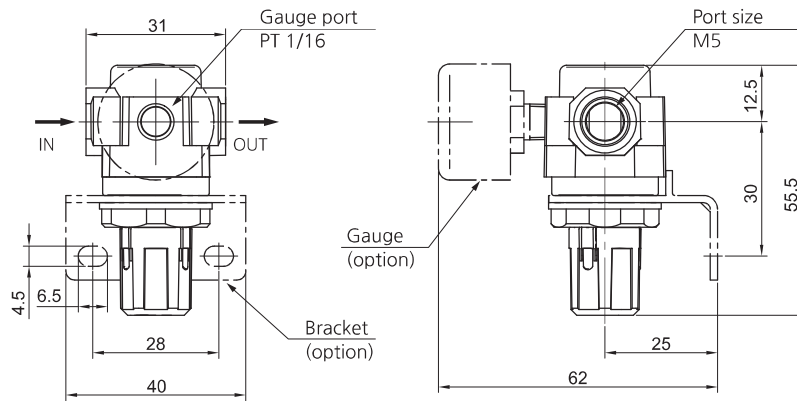

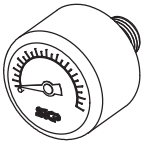
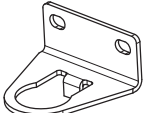
Option	G : Round type Gauge	B : Bracket
Model	 <p>Model : G25 R 1/16</p>	 <p>B120</p>

# Series SAR100~600

## DIMENSIONS (mm)

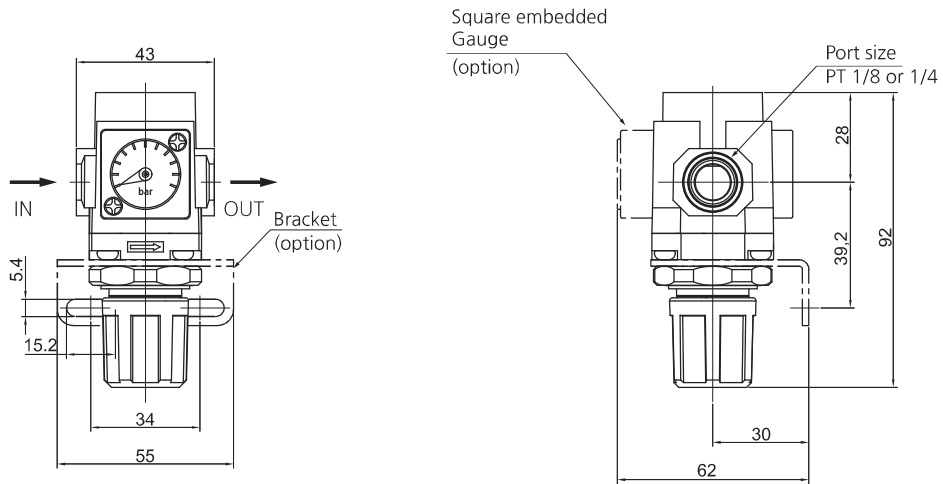

### SAR 200

- SAR200-□02□□

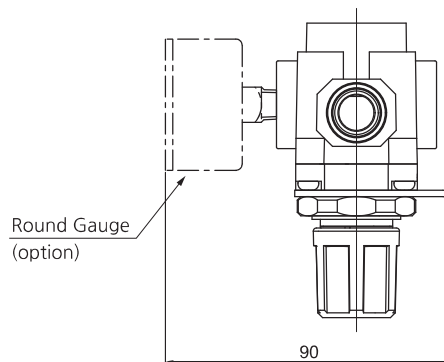

- Dimensions of each model with an option attached



Option	Gs : Square embedded Gauge	G : Round type Gauge	B : Bracket
Model	 Gs28	 G40, R1/8	 B220

## DIMENSIONS (mm)

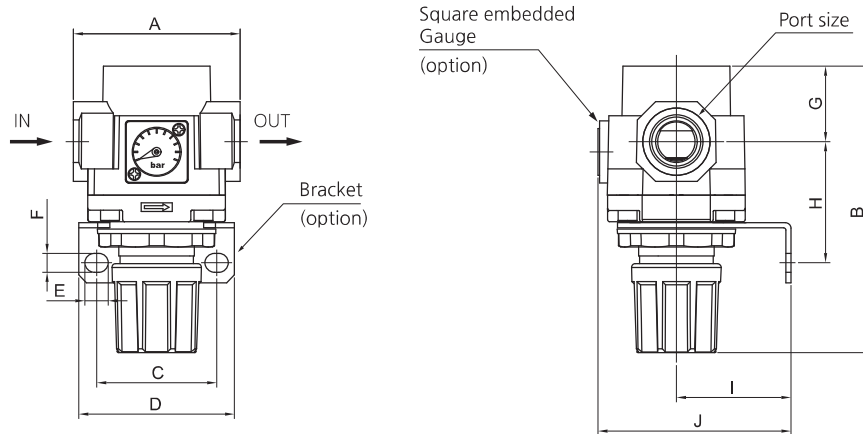

### SAR 300~400

- SAR300-□03□□
- SAR400-□04(06)□□

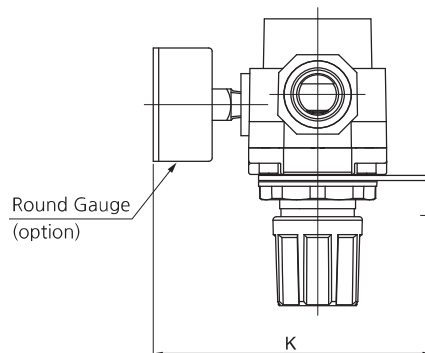

- Dimensions of each model with an option attached



Option	G : Square embedded type Gauge	G : Round type Gauge	B : Bracket
Model	 Gs28	 SAR300 : G40, R1/8 SAR400 : G50, R1/4	 SAR300 : B320 SAR400 : B420

Model	Port size	A	B	C	D	E	F	G	H	I	J	K
SAR300-03	1/4, 3/8	57	117	40	53	8	6.5	28.4	45.7	41	72	107
SAR400-04	1/2	75	125	54	70	10.5	8.5	34	54	50	87	127
SAR400-06	3/4	75	127	54	70	10.5	8.5	34.5	55.5	50	87	127

# Series SAR100~600

## DIMENSIONS (mm)

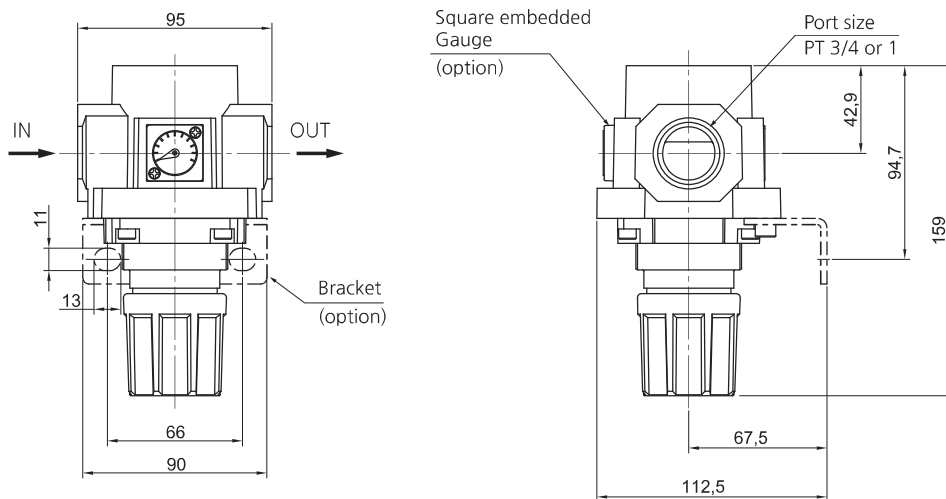

### SAR 600

- SAR600-□06□□
- SAR600-□10□□

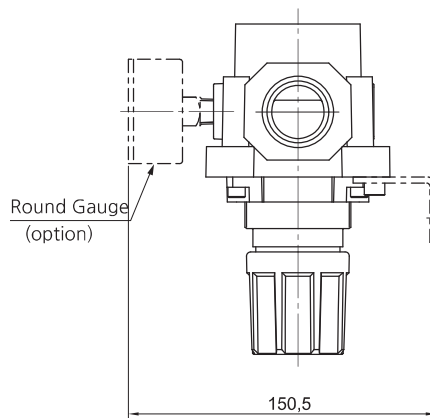

- Dimensions of each model with an option attached

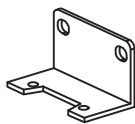

Option	G : Square embedded type Gauge	G : Round type Gauge	B : Bracket
Model	 Gs28	 G50, R1/4	 B600