

Mist Separator (SAM)

SAM150~850 Series



150-550 series can be combined with other modular equipment.

- SAM series eliminates micro-particles such as rust, carbon of 0.1 micron or greater, etc. by separating oil mist that normal air filters may have difficulty removing.
- SAM series is the optimal filter for use with any air source that drives solenoid valves of pilot type, and metal seal type.

How to order

SAM 350 - 03 BD - MeP - S

① Mist Separator

② Body Size

- 150 - 1/8
- 250 - 1/4
- 350 - 1/2
- 450 - 3/4
- 550 - 1
- 650 - 1 1/2
- 850 - 2

③ Thread type

- Nil - Rc(PT)
- N - NPT
- G - G(PF)

④ Port Size

Symbol	Size	Body size					
		150	250	350	450	550	650/850
01	1/8	●					
02	1/4	●	●				
03	3/8		●	●			
04	1/2			●			
06	3/4				●	●	
10	1					●	
12	1 1/4						●
14	1 1/2						● ●
20	2						●

⑤ Accessory(Optional)

- Nil - None Bracket / Manual Drain
- B - Bracket
- D - Auto Drain

Symbol	Drain connector	Material
D	One-touch fitting(Φ6mm)	Acetal
Dn	Nipple(PT 1/8)	Brass

⑥ Bowl

- Nil - Metal bowl with flat type sight glass(MeF)
- PcS - Polycarbonate bowl with Steel guard
- MeP - Metal bowl with pipe type sight glass

(Note) 150 and 250 are the integral cover and bowl(MeF type).

⑦ Option

- Nil - None
- S - Differential Pressure Indicator

Symbol



Specification

Fluid	Compressed Air
Max. operating pressure	10bar (1.0MPa)
Min. operating pressure	1.5bar (0.15MPa)
Max. supply pressure	15bar (1.5MPa)
Ambient and Media temp.	5~60℃
Filtration	0.1μm (Filtration efficiency: 99%)
Life of element	When pressure drop reached at 1bar

Precautions

- ① Filter element should be changed after 2years of use or when pressure drop reached at 1bar(0.1MPa).
- ② When auto drain is used, drain piping should be both 4mm or greater in diameter and less than 1m in length. Avoid installing drain piping upwards.
- ③ When auto drain is used it is recommended to use at least 1.5bar pressure.
- ④ When auto drain is inoperable, drain manually by pushing the one-touch fitting upward.
- ⑤ Before disassembling the equipment on the compressed air side to inspect the auto drain or to replace the filter element, confirm that the pressure is set to zero.
- ⑥ Please consult with SKP when using the product in applications other than compressed air.

Series SAM

FLOW CHARACTERISTICS Oil saturated state of element

Note : If compressed air is above max. flow, mist separator cannot be operated well or element may be damaged.

SAM 150

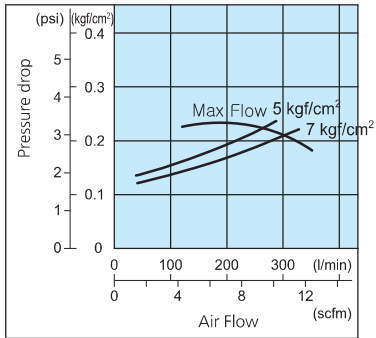

SAM 250

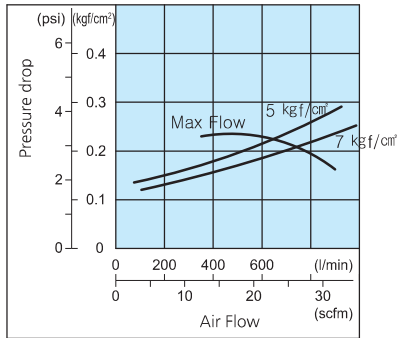

SAM 350

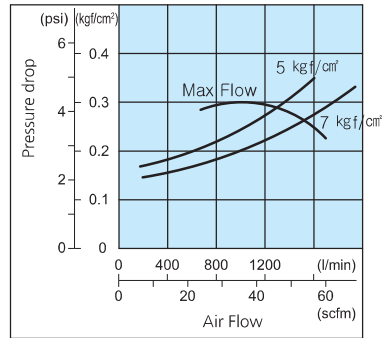

SAM 450

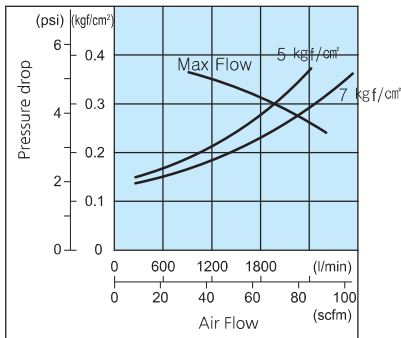

SAM 550

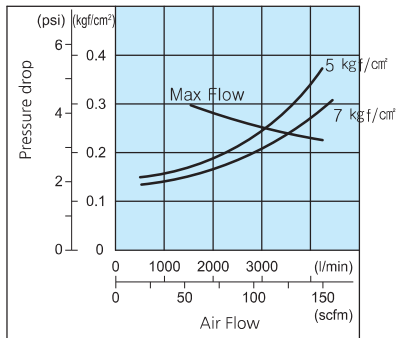

SAM 650

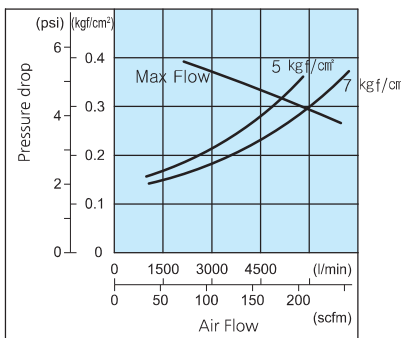

SAM 850

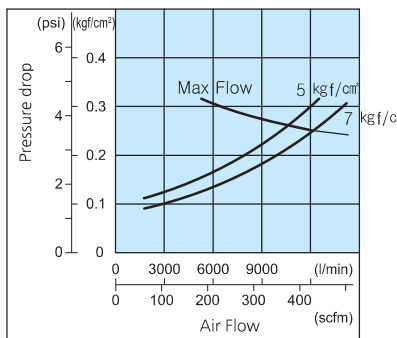

STRUCTURE / PARTS

SAM 150~250

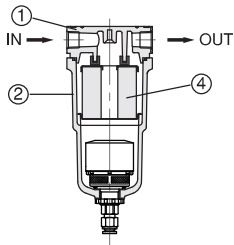

SAM 350~550

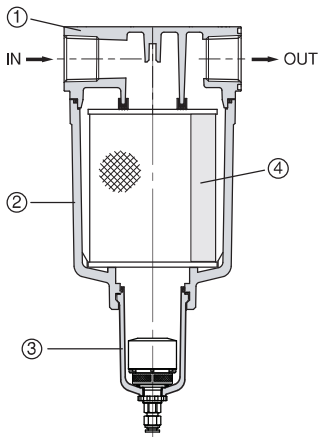

SAM 650~850

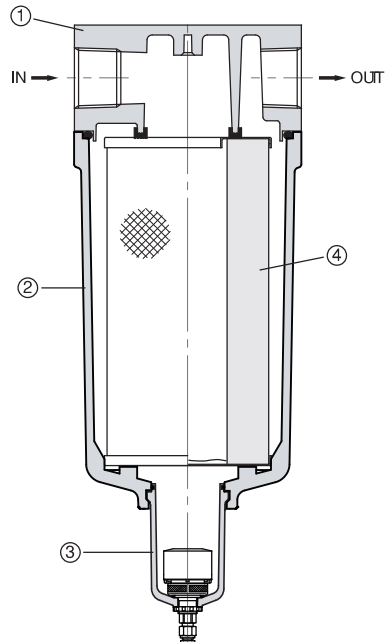

▪ **Component Parts**

No.	PARTS	MATERIAL
①	Body	ALDC
②	Housing	ALDC
③	Bowl Ass'y	ALDC(MeP type)
		ALDC(MeF type)

▪ **Replacement Parts**

(mm)

No.	PARTS	Part No. & Size(Φ x Height)						
		AM-EL150	AM-EL250	AM-EL350	AM-EL450	AM-EL550	AM-EL650	AM-EL850
④	Filter	45 x 42	58 x 52.5	70 x 77	82 x 87	95 x 117	122 x 144	130 x 260

▪ **Sectional drawing (SAM Filter)**

- 1) Porous Plastic Coalescing Stage**
 - Oleophilic Porous Plastic core.
 - In addition to removing particulates down to 40 μ m.
- 2) Remove Oil Media**
 - 0.3 μ m remove oil micro fiber media.
 - Coalescing element designed to remove oil and water aerosol from process air or gas.
- 3) Main Media**
 - Three element choices(0.01 μ m (AMD), 0.1 μ m (AM), 1 μ m (AFL)).
 - Pure borosilicate glass micro fiber.
- 4) Drain Layer**
 - Non-wetting fiber drain layer.
- 5) Porous Plastic Coalescing Stage**
 - In addition to removing particulates down to 40 μ m.
- 6) Coated Mesh**

Series SAM

DIMENSIONS (mm)

SAM 150~550

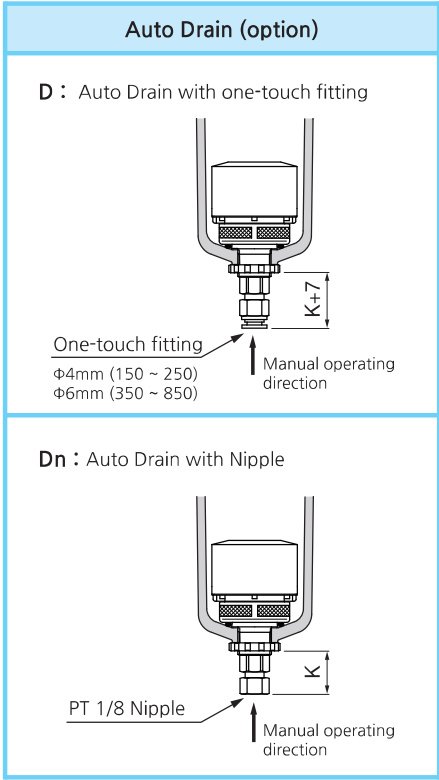
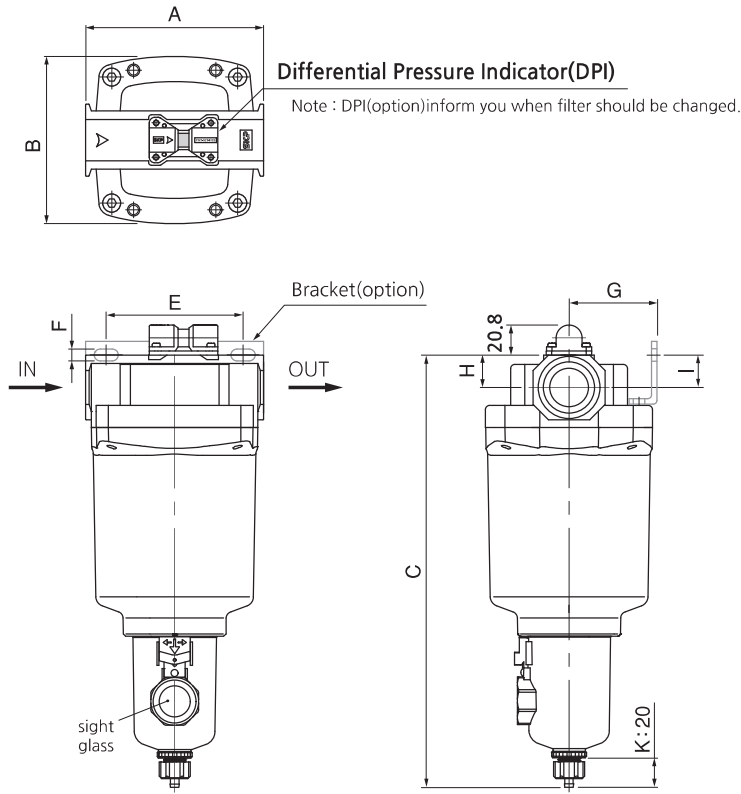

- MeP - Metal Bowl with pipe type sight glass

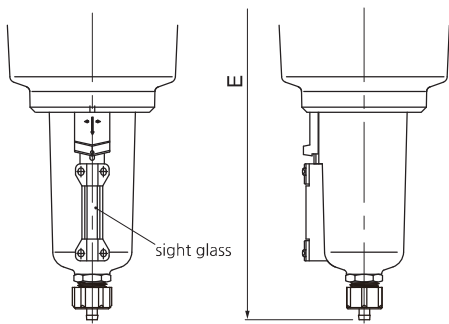

Note : 150 and 250 are the integral cover and bowl(MeF type)

Model	Port size	A	B	Height(manual drain)		E	F	G	H	I
				C(MeF)	D(MeP)					
SAM 150	1/8, 1/4	67	66	158.5	-	56	6	33.6	10.5	19.7
SAM 250	1/4, 3/8	82	76	177.7	-	66	6	39.5	14	13.5
SAM 350	3/8, 1/2	98	90	253	273	80	7	49.8	17.9	15.9
SAM 450	3/4	114	106	271.3	291.3	90	9	56.2	19.8	15.3
SAM 550	3/4, 1	130	122	311.2	331.2	100	8.8	64.5	23.7	21

DIMENSIONS (mm)

SAM 650~850

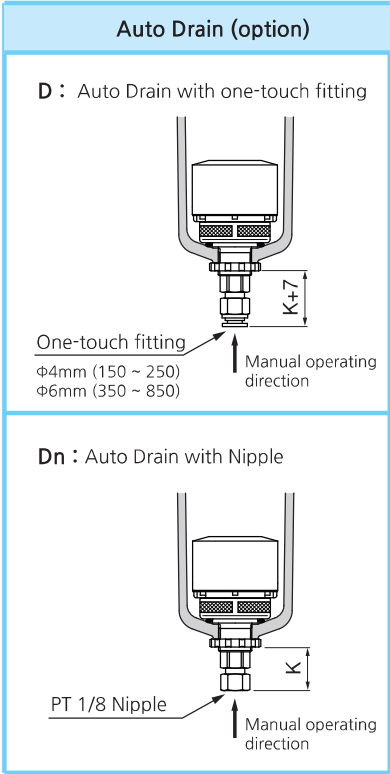
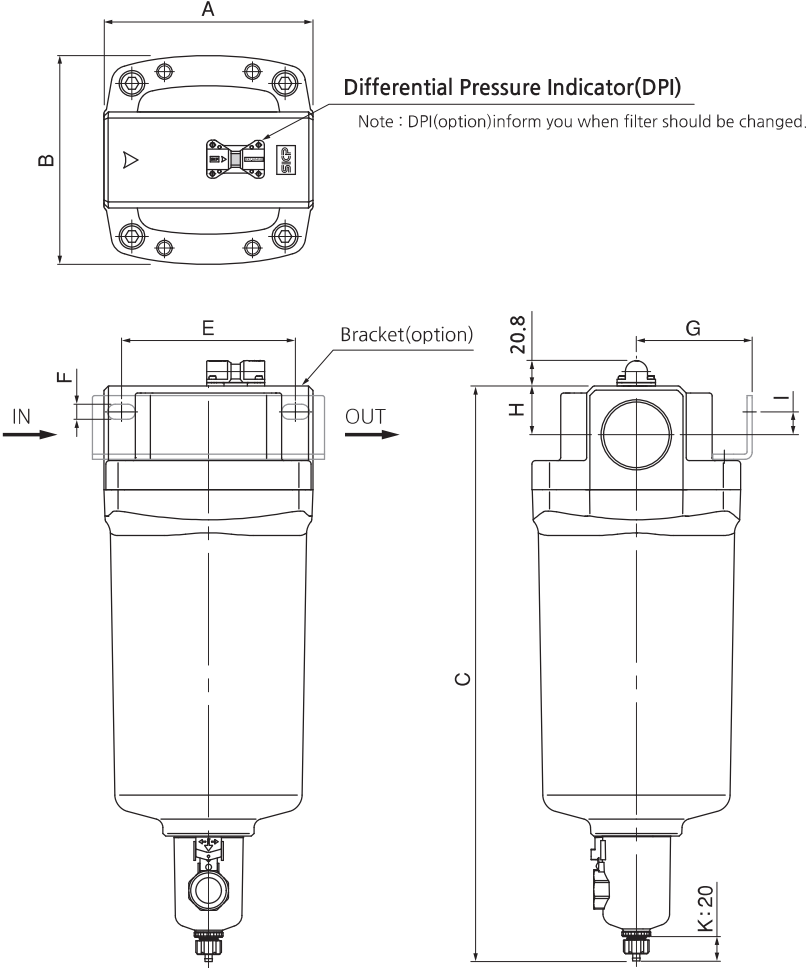

- MeP - Metal Bowl with pipe type sight glass

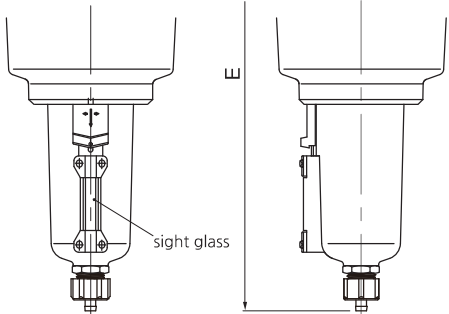

Model	Port size	A	B	Height(manual drain)		E	F	G	H	I
				C(MeF)	D(MeP)					
SAM 650	1 1/4, 1 1/2	160	160	361.2	381.2	150	13	93	32	27
SAM 850	1 1/2, 2	180	180	490.7	510.7	150	13	100	42	20