

# Solenoid valves for steam and high temperatures

3/2 way - Normally Closed - Direct Operated

Flange fittings

Series **128**

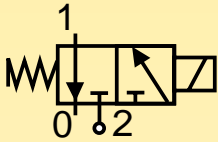

**N.C.**

**Normally closed**

Coil energised - open

Coil de-energised - closed

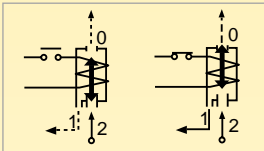

## General description:

PARKER series 128 solenoid valves are direct operated and do not require a minimum differential pressure to operate. They are used for **superheated water**. Series 128 valves are **normally closed**. The inlet and outlet fittings are situated on the mounting flange and enclosing tube.

## Temperatures:

The working temperature for media is:

maximum	<b>+140°C</b>
minimum	<b>-30°C (Ruby)</b>
minimum	<b>-10°C (FKM)</b>

The maximum ambient temperature is:

- with class "F" coils **+50°C**
- with class "H" coils **+80°C**

## Application:

Series 128 solenoid valves are ideal for automatic control of superheated water for dispensing espresso coffee. Models are available with various seals and fitting configurations for maximum flexibility of application and installation. Some typical application examples:

- Espresso coffee machines, for bars;
- Espresso coffee machines, for the home;
- Automatic dispensers.



## Coils:

For series 128 valves class "F" coils (**155°C**) are available encapsulated in thermoplastic containing 30% glass fiber, (ZB, YB types). Class "H" coils (**180°C**) are available encapsulated in thermoplastic containing 40% of glass fiber (ZH type). All the coils are for continuous service, 100% E.D. The rated voltage tolerance is: **±10% for A.C.** power supply and **+10% -5% for D.C.** The "Z" and "Y" coils can be used on a.c. with a frequency of 50/60 Hz (dual frequency). The "Z" coils have Faston terminals for **DIN 43650A** connectors with protection to **IP65**. The "Y" coil has terminals with 2 x 1,000 mm cables with protection to **IP67**.

## Installation:

The valves can be mounted in any position without jeopardising their operation. It is however advisable to install them with the coil in a vertical position above the body.

## Approvals:

-  • For the coils:
  - ZB 09** 115V/50-60Hz, 220-230V/50-60Hz, 240V/50-60Hz
  - ZH 09** 24V/50-60Hz
  - ZH 12** 12VDC, 24VDC
  - YB 09** 220-230V/50-60Hz
-  • For the coils:
  - ZB 09** 220-230V/50-60Hz, 240V/50-60Hz
  - YB 09** 220-230V/50-60Hz
-  • UL Recognized Comp. coils mark:
  - ZB 09** 24V/60Hz, 110-120V/60Hz, 208-240V/60Hz
  - YB 09** 24V/60Hz, 110-120V/60Hz, 208-240V/60Hz



Series **128**

**MATERIALS**

- Valve body: CW617N UNI EN 12165:98 brass stamping
- Seals: Ruby - Viton
- Enclosing tube: AISI 304 stainless steel
- Plunger: AISI 430F stainless steel
- Spring: AISI 302 stainless steel
- Shading ring: Copper
- Fitted sit: AISI 304 stainless steel

**ELECTRICAL FEATURES**

Coil type [ ]		Power [ W ]		Insulat. class
A.C.(~)	D.C.(=)	A.C.(~)	D.C.(=)	
ZB 09	ZB 12	9	12	F
YB 09	YB 12	9	12	F
ZH 09	ZH 12	9	12	H
ZH 14	ZH 16	14	16	H

**SPECIFICATION**

Fittings Ø G	Valve type	Nominal orifice Ø	Flow coefficient Kv	Minimum pressure	Max differential pressure (M.O.P.D.)		Coil type	Weight	Notes
					in A.C.(~) [bar]	in D.C.(=) [bar]			
[ " ]	[ ]	[mm]	[m³/h]	[bar]			[ ]	[Kg]	[ ]
-	128 I	1,3 - (2,5)*	0,070	0	10	10	Z - Y	0,310	1 - 2
-	128 G	1,3 - (2,5)*	0,070	0	10	10	Z - Y	0,310	1 - 2
-	128 I-UL	1,3 - (2,5)*	0,070	0	10	10	Z - UL	0,310	1 - 2
-	128 G-UL	1,3 - (2,5)*	0,070	0	10	10	Z - UL	0,310	1 - 2

Note: 1) NP (nominal pressure): 25 bar.  
2) Maximum static pressure 14.5 bar (for Viton sealing, maximum static pressure: 12 bar). (\*) Diameter of the discharge.

**DIMENSIONS**

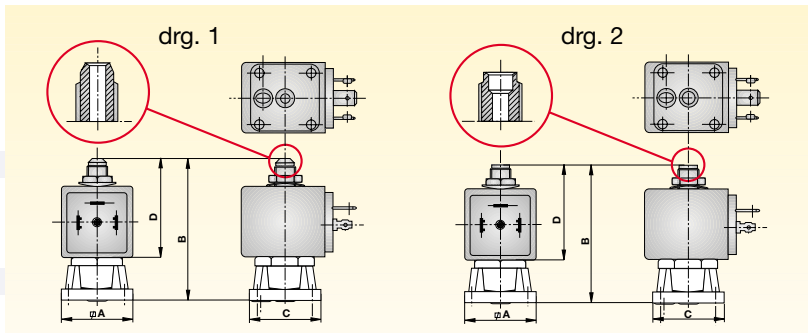

TYPE	A	B	C	D
[ " ]	[mm]	[mm]	[mm]	[mm]
128 I	32	66	32	45,5
128 G*	32	63,5	32	43
*drg. 2				

**ORDER CODE**

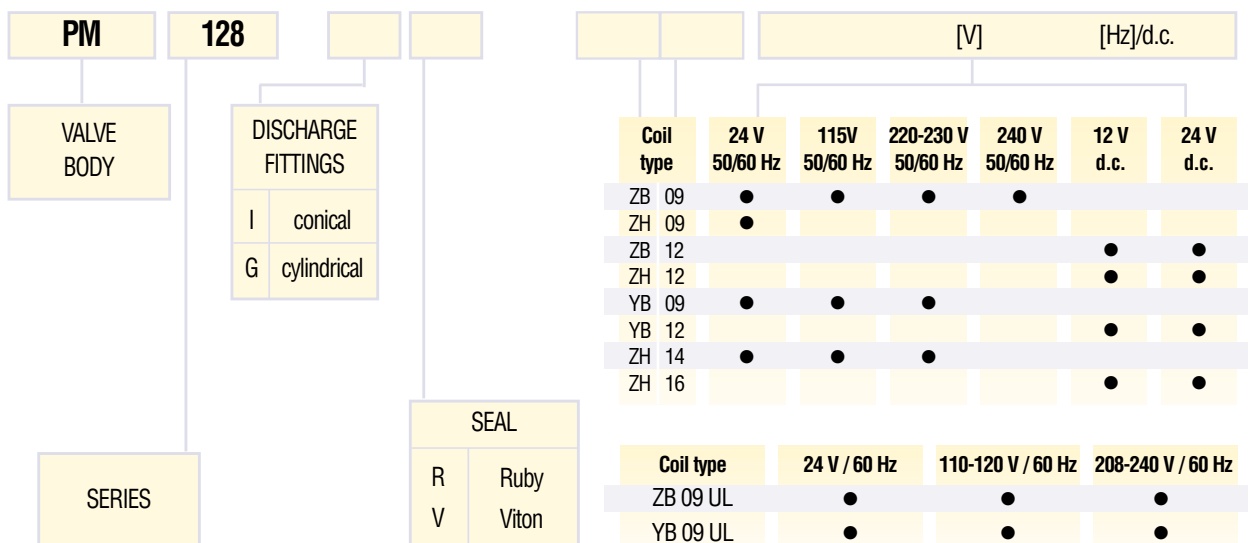

Note: Valves supplied with coils in a multipack. Connectors to be ordered separately.